



800 BAR

# TORQUE PUMP

USER MANUAL

# TABLE OF CONTENTS

Introduction.....	Page 2
General Description.....	Page 3
Components.....	Page 5
Warnings and Cautions.....	Page 6
Operation Instructions.....	Page 7
Trouble Shooting.....	Page 8
Maintenance.....	Page 9
Transport.....	Page 11
Scrapping.....	Page 12
User Manual and settings.....	Page 12

# INTRODUCTION

The user manual is important for the use and understanding of the Grene WIS 800 bar Torque Pump.

The purpose of these instructions is to ensure the correct use, handling, and maintenance of the torque pump.

The manual must be kept in a place known to staff, where they are easily accessible to operators.

The owner of the torque pump is obliged to ensure that everyone who shall operate the machine has read the manual.

If the torque pump is not operated by personal that have learned how to use it, the results will be influenced by that.

## DISTRIBUTOR

Grene Wind Industry Supplies A/S

Tinvej 2, 8940 Randers SV,  
Denmark

Mail: [wis.dk@grene.com](mailto:wis.dk@grene.com)

Tel: +45 86 44 20 55

## PARTNUMBER

0070WIS2100P



# GENERAL DESCRIPTION

The Grene WIS Torque Pump is a specially designed pump for hydraulic wrenches. It consists of a hydraulic piston pump, electrical motor, cooler, valve manifold and controller, together with an aluminum tank and frame to secure the light weight and high hydraulic pressure.

The high- and low-pressure pump supply oil at all time, so it can achieve high output. In high pressure, the low-pressure pump returns oil with minimum of load automatically through a relief valve to reduce power consumption.

The low-pressure pump will automatically enable when the high pressure disables, to secure a fast return to start position of the wrench.

The high-pressure pump has three different flow levels at different pressure levels, to secure maximum flow at all time and pressures.

## TECHNICAL SPECIFICATIONS

Main pressure	70-800 bar
Secondary pressure	approx. 90 bar
Pressure Gauge	0-1000 bar
Motor	1,5kw motor 230VAC / 50hz
Power supply	1x230VAC / 50hz
Cooler fan (Single phase)	38W fan 220VAC 50hz
One directional valve	24VDC 0,77A

Supply cable	4 mtr. + equipped with a CEE plug
Controller cable	4 mtr.
Working temperature	-10° - +60°
3 stage pump	<ul style="list-style-type: none"> <li>• 8l/min up to 100 bar,</li> <li>• 1,6l/min up to 320bar</li> <li>• 0,8l/min up to 800 bars</li> </ul>
Tank volume	8 L
Approx. weight	32kg

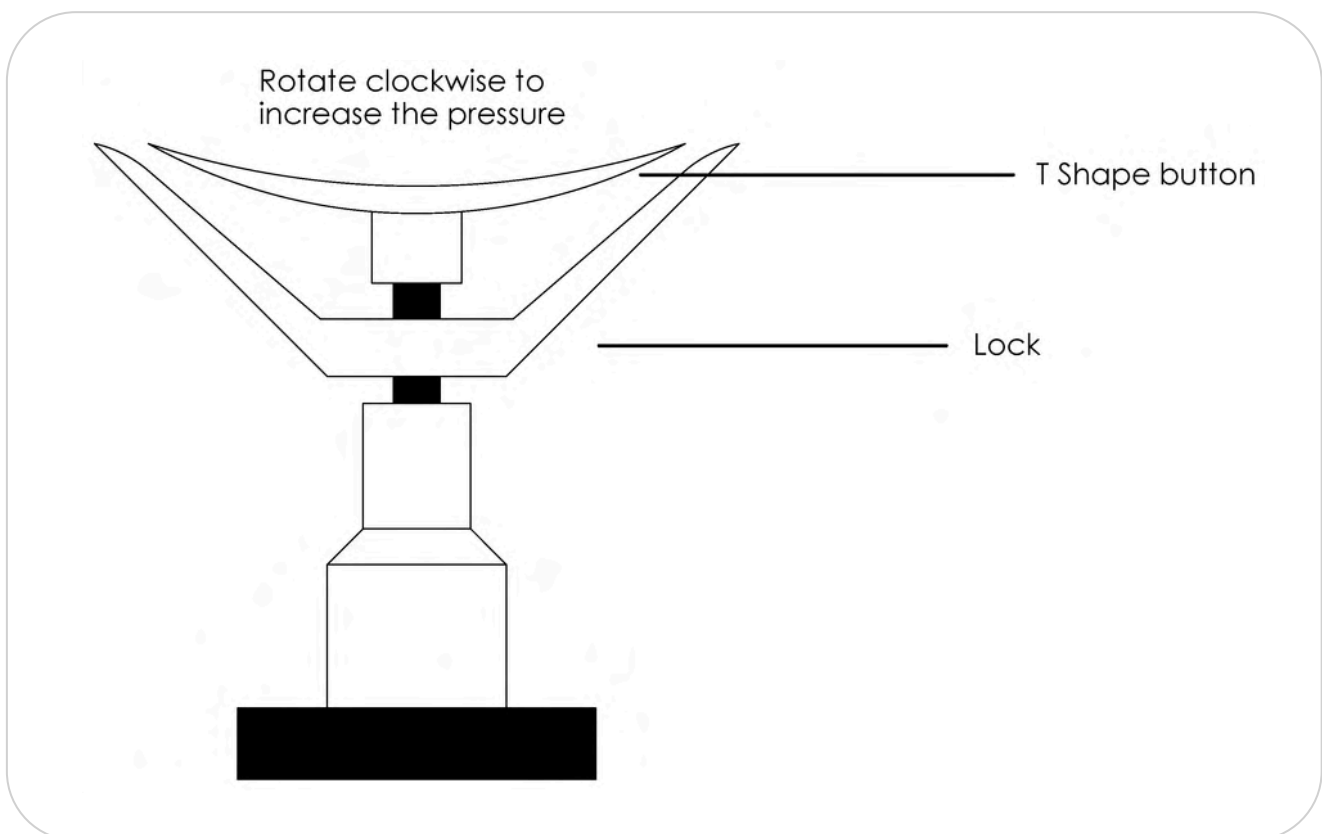

# COMPONENTS

**Pos. 1:** A / B ports

**Pos. 2:** Level Gauge

**Pos. 3:** Relief Valve

**Pos. 4:** Tank Cap / Oil Filler

**Pos. 5:** Motor 1 phase

**Pos. 6:** Cooler 1 phase

**Pos. 7:** Electrical controller

**Pos. 8:** Pressure Gauge

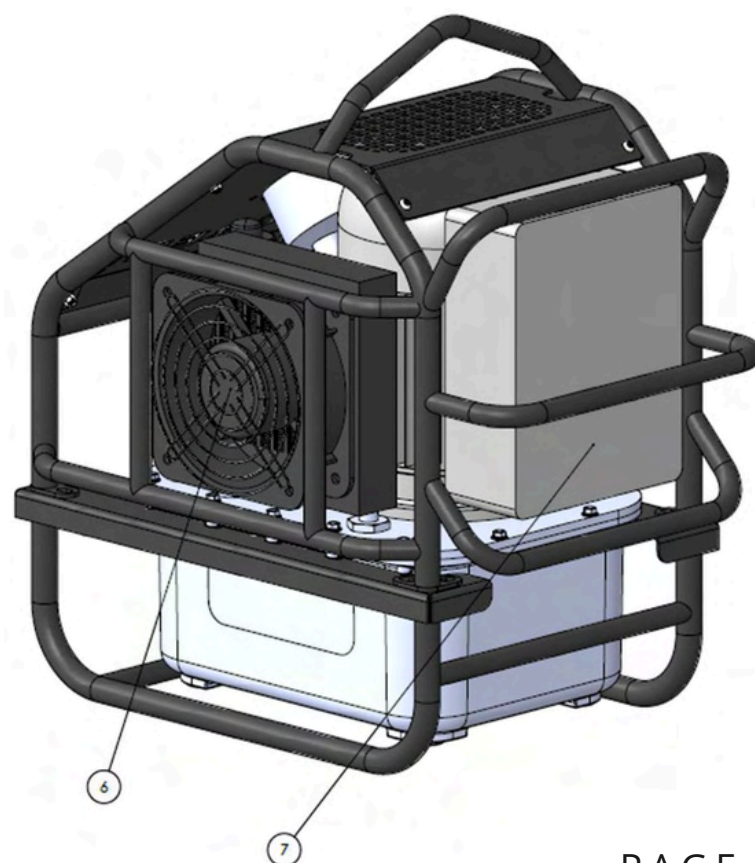
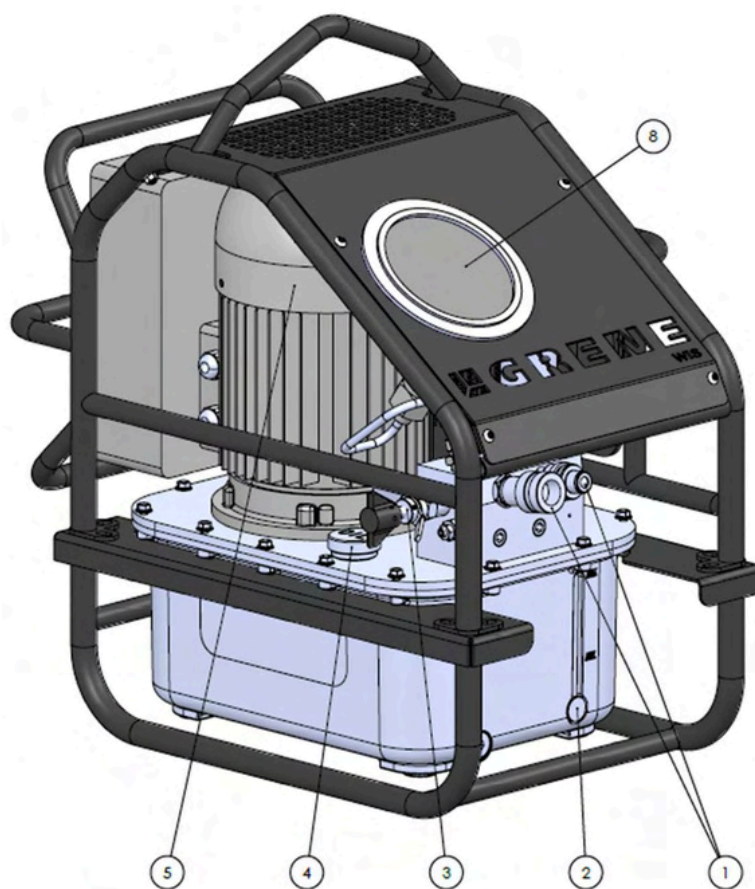



## **WARNINGS AND CAUTIONS**

- 1) Hoses and quick couplers should be fastened before starting.
- 2) Make sure the quick couplers are fastened very well, otherwise it may not work normally.
- 3) The maximum working pressure of this pump is 800 bar, it is not allowed to adjust it higher than the 800 bar.
- 4) If this torque pump is used for other equipment, with working pressure less than 800 bar, please adjust the pressure to match it. Otherwise, the equipment can be damaged.
- 5) Please disconnect power before repair.
- 6) Make sure power supply is grounded.
- 7) It's not allowed to modify the pump.
- 8) Do not put more hydraulic oil on pump than maximum fill level. Otherwise, oil will leak and pressure increase.
- 9) Please wash your eyes if any oil splashes and go to the hospital if necessary.



# OPERATION INSTRUCTIONS

- 1) Fill tank with oil, not beyond maximum level of gauge.
- 2) Use a mineral hydraulic oil viscosity 46. Please choose an oil with a high viscosity index.
- 3) Recommended oil cleanness when filled, ISO 4406- Code 17/15/12 or better.
- 4) Connect hoses and check the hoses if all connections are good.  
Use A port for tightening and B port for release.
- 5) Check if the power voltage matches the motor unit and connect power cable to source.
- 6) Press "UP" once and the motor starts, now the oil flow to port B and releases the tool.
- 7) When ready, press and hold "UP" until the tool reaches the tighten limit and let go of the "UP" button again.
- 8) The tool will now release and when fully released, please press and hold "UP" again.
- 9) Please continue this until finished.
- 10) Press "DOWN" to stop motor
- 11) E-Stop is not attended as a stop button, it is for emergency only.





# **TROUBLE SHOOTING**

## **THE TORQUE PUMP CANNOT BE STARTED**

- 1) The power voltage is wrong – Please check voltage
- 2) The power is not connected – Please check all connections and check for light.
- 3) The fuse is broken – please check if fuse is defect and if please change fuse.

## **SYSTEM PRESSURE CANNOT BE REACHED**

- 1) Quick couplers are not connected properly – Please disconnect couplers and connect again.
- 2) No oil or not enough oil in tank – Please refill oil
- 3) Water in the oil, oil looks “white” – Please change oil.
- 4) Relief valve is not adjusted – Please check relief valve and adjust.
- 5) Air in the system – Run the system back and forth several times to let the air out.

## **SYSTEM PRESSURE GOES DOWN IN STATIC PRESSURE**

- 1) Seals or pump damage – pump / seal repair.



# **MAINTENANCE**

## **BEFORE OPERATION**

- 1) Check if the power is connected well
- 2) Check if the hydraulic oil level is ok.
- 3) Check if pressure is ok when starting the motor.
- 4) Check if there are any leakages.

## **IN OPERATION, PLEASE CHECK FOLLOWING THINGS AND STOP IF OCCURS**

- 1) If any abnormal condition when making pressure.
- 2) If any leakage of hose or equipment.
- 3) If any abnormal noises, shock or smell when motor is working.
- 4) If the oil temperature stays too high.

## **AFTER OPERATION**

- 1) Cut off the power.
- 2) Check for any leakages.
- 3) Clean after use.

## **THE HYDRAULIC OIL SHOULD BE CHANGED TWICE A YEAR OR IMMEDIATELY IF**

- 1) Oil contaminated dust or other fragments.
- 2) Oil smells abnormal.
- 3) Oil becomes milk white, water comes in.
- 4) Oil changes color, because of temperature or contaminations.

## **IN OPERATION, PLEASE CHECK FOLLOWING THINGS AND STOP IF OCCURS**

- 1) Open the tank cap
- 2) Dismount the tank plug and let the oil flow out.
- 3) If necessary; clean inside tank and filter net.
- 4) Install the tank plug and put oil into tank again.



## TRANSPORT

- Transport and in general, place the torque pump on the positions marked with **green** here below
- Lifting by crane / hook, use the position marked with **blue**
- Manuel handling, please use positions marked with **red**

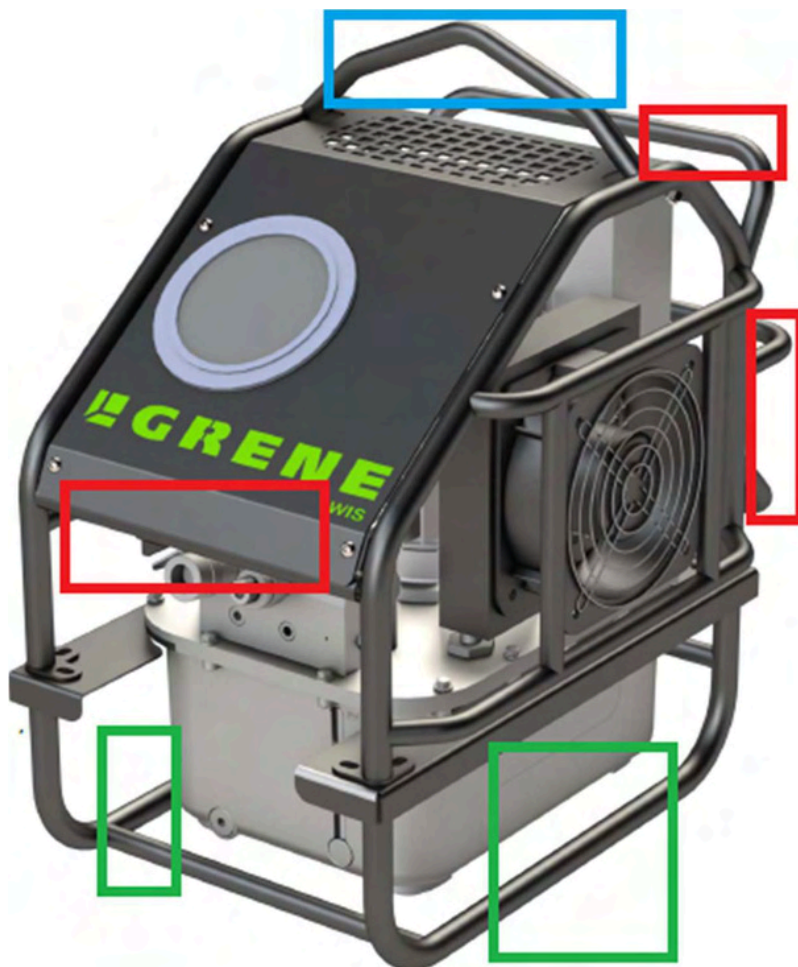



## **SCRAPPING**

The Grene WIS Torque pump consists of steel parts, plastic/rubber parts and electrical parts, all of which are recyclable.

Once all the oil has been drained, the rest of the pump can be disposed in different fragments.

## **USER MANUAL AND SETTINGS**

Please note that the information in this user manual can change without notice.

The information in this user manual is in general terms, errors and omissions may occur.

# **C O N T A C T**

## **Grene Wind Industry Supplies A/S**

Tinvej 2,  
DK-8940 Randers SV,  
Denmark

Mail: [wis.dk@grene.com](mailto:wis.dk@grene.com)

Tel: +45 86 44 20 55

